

- 1
- 2
- 3
- 4
- 5
- 6
- 7
- 8
- 9
- 10
- 11
- 12
- 13
- 14
- 15
- 16
- 17
- 18
- 19

**SPECIFICATION**

Stainless Steel AISI 304  
matte, tumbled finish **MT**

Countersunk screw DIN 7991  
Stainless Steel AISI 304

Half-length tapered groove pin DIN 8745  
Stainless Steel AISI 304

**INFORMATION**

The GN 784.1 flanges are mounted from below onto the swivel ball joints GN 784 (see page -). A half-length tapered groove pin prevents any rotation. The flange enables the swivel ball joints to be mounted on the upper surface.

The d2 section with the three d3 drill holes is configured so that standard screws with washers can be used.

The countersunk screw is included separately.

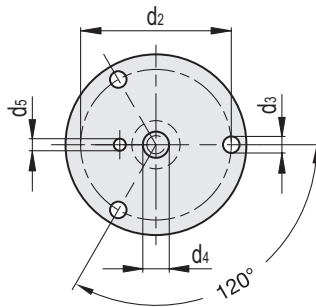
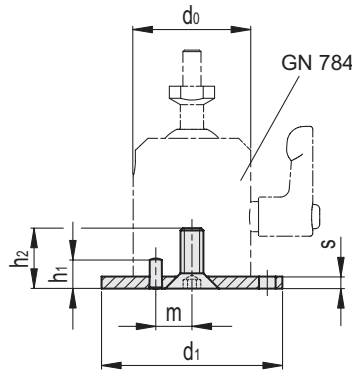
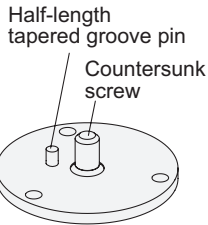

Conversion Table	
1 mm = 0,039 inch	
d1	
mm	inch
42	1.64
49	1.91
60	2.34
70	2.73

Code	Description	d0	d1	d2	d3	d4
GN.79251	GN 784.1-42-MT	23	42	32.5	4.5	M5
GN.79253	GN 784.1-49-MT	31	49	40	4.5	M6
GN.79255	GN 784.1-60-MT	39	60	50	5.5	M8
GN.79257	GN 784.1-70-MT	49	70	60	5.5	M8